

Symbol Tunnus	Var tidigare Oli ennen	Dat. Pvm.	Andr. Teki	Symbol Tunnus	Var tidigare Oli ennen	Dat. Pvm.	Andr. Teki	Symbol Tunnus	Var tidigare Oli ennen	Dat. Pvm.	Andr. Teki
---------------	------------------------	-----------	------------	---------------	------------------------	-----------	------------	---------------	------------------------	-----------	------------

MOUNTING INSTRUCTIONS

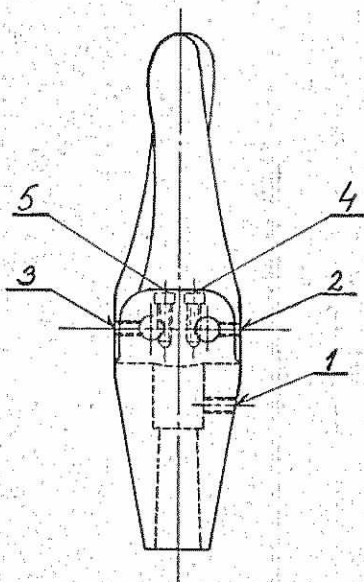

- THE BLADES ARE REMOVED FROM THE BOSS BY LOOSENING THE LOCK SCREWS 2 AND 3, AND THE HEXAGON SOCKET SCREWS 4 AND 5, AFTER WHICH THE PINS CAN BE PUSHED OUT. PIN AND CORRESPONDING BLADE ARE MARKED TO ENSURE THAT THEY ARE CORRECTLY PLACED AT REASSEMBLY.
- THE KEY IS PLACED IN ITS SLOT ON THE SHAFT, AND THE BOSS IS THEN PUSHED ONTO THE SHAFT. THE LOCK SCREW 1 MUST BE LOOSENED. THE NUT ON THE SHAFT END IS PUT ON AND TIGHTENED PROPERLY.
- PUT ON THE BLADES AND INSERT THEIR PINS, TAKING CARE TO GET THE INDENTATION FOR THE LOCK SCREWS CORRECTLY PLACED.
- THE LOCK SCREWS 1, 2 AND 3 ARE SCREWED IN PLACE (2 SCREWS FOR EACH HOLE). FINALLY SCREW IN THE TWO HEXAGON SOCKET SCREWS.  
IMPORTANT! THE SCREWS MUST BE SECURED BY LOCTITE TYPE SCREWLOCK OR SIMILAR. PEENING THE EDGES IS NOT RECOMMENDED AS IT MAKES IT VERY DIFFICULT TO REMOVE THE SCREWS LATER.
- FINALLY, CHECK THAT THE BLADES CAN MOVE FREELY.

Antal per båt Lukumäärä per vene		Benämning Nimitys	Ritn. nr Piir. no	Material Aines	Mått Mitat	Pos. Viite
		Rit. Piir. 28/8-75	Skala Suhde	Anm. Huom.		
		Gransk. Tark.				
		Godk. Hyv.				
		<b>NAUTOR</b> OY Wm. Schauman AB	NAUTOMATIC FOLDING PROPELLER		Ersätter Korvaa	
					Nr No	4-42-081 B
					Ersatt av Korvattu	
Båttyp Venetyyppi					H	A
					G	
					F	
					E	
					D	
					C	
					B	